

FIELD LEVEL OVERSIZE FENCE PIN INSTALLATION

17/32" & 9/16" DIAMETER OVERSIZE PINS ARE AVAILABLE

1. Check fence blade Z-83 for straightness, if not straight, have it blanchard ground.
2. Redrill the pin hole in the Z-16, lower spider, that is the closest to the operator. (See figure #1) This should be done in a good straight drill press with 17/32" or 9/16" multiflute drill bit provided. **DO NOT DRILL** the rear hole at this time. **Note:** The fence does not have to be disassembled to do this.
3. Position the Z-16 lower spider on the table top using the old pin in the rear hole. (See figure #2) Use the rear pin as an aid in positioning the redrilled front hole, which will be used as a drill bushing. Redrill all the table holes on both sides of the blade. **Note:** When you shift the Z-16 to the left side of the blade, you will be redrilling the rear row of holes.
4. When all the holes on the one side are redrilled, take the Z-16 lower spider back to the drill press and redrill the rear hole in the same manner as the front hole. (See figure #3)
5. Using the provided dovetail slot stops, slide them into the appropriate slot for the fence position that you are going to finish. What you will have to provide yourself are parallel panels or boards that are used to align the fence to the dovetail slot at the various fence positionings.

Put an oversize pin in the front holes that you have redrilled, advance the fence until it sits squarely on your spacer material that is butted against the dovetail stops. (See figure #4) Use a 1/2" bolt and a washer through the slot in the Z-16 lower spider to hold it in this position. Take the 17/32" or 9/16" multiflute drill and hand drill the table hole through the redrilled boss in the lower fence spider. Repeat this procedure for the remainder of the holes using appropriate parallels for each position.

1

FIRST REDRILL THIS HOLE USING DRILL PRESS

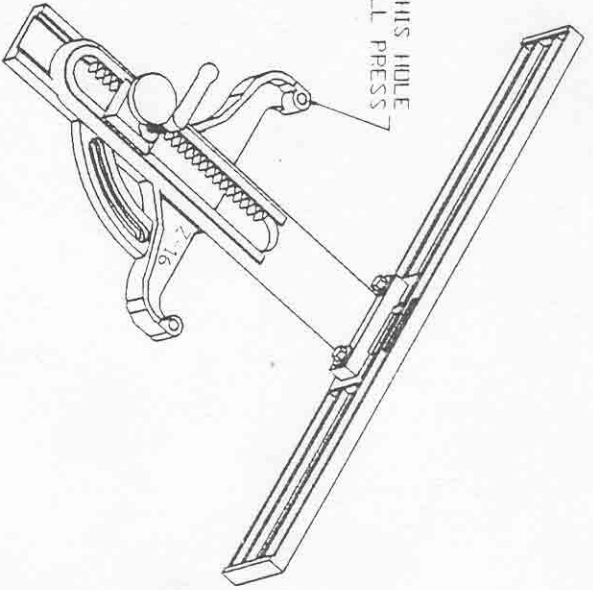

2

USE 6" HAND WHEEL & Ø17/32 PEANER TO REDRILL HOLES IN TABLE

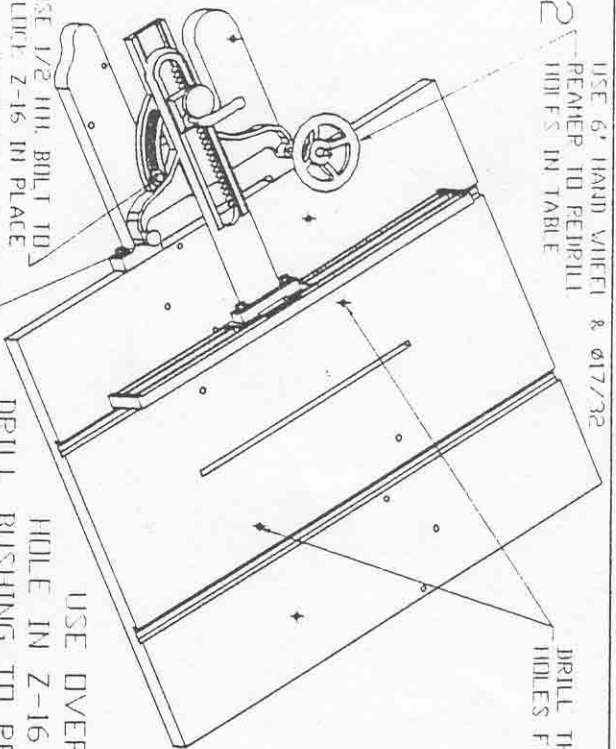

USE 1/2" DIA. BOLT TO LOCATE Z-16 IN PLACE USE OLD PIN IN Z-16 AS A POSITION AID

USE OVER SIZE HOLE IN Z-16 AS A DRILL BUSHING TO REDRILL THE MATING HOLES IN TABLE

3

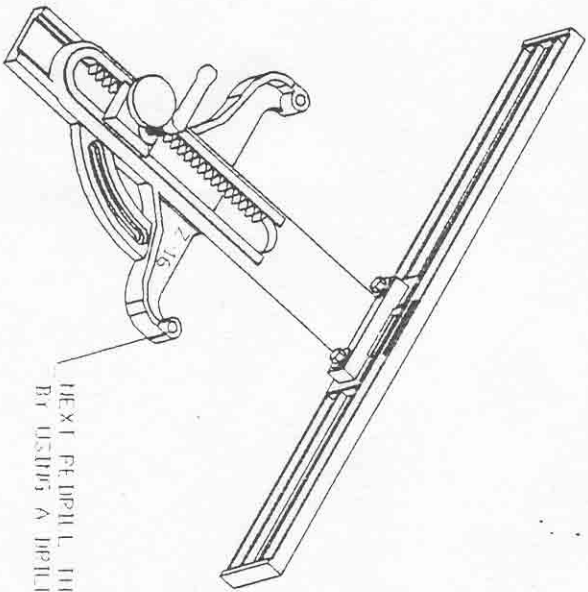

NEXT REDRILL THIS HOLE BY USING A DRILL PRESS

4

USE DOVETAIL STOPS AND PARALLELS TO ALIGN FENCE WITH SLOT IN TABLE

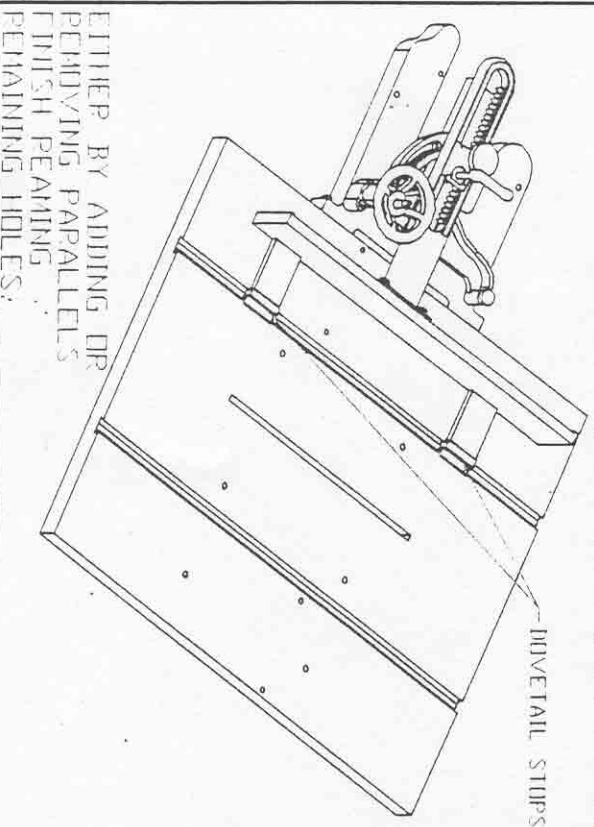

EITHER BY ADDING OR REMOVING PARALLELS FINISH PEAMING REMAINING HOLES: