

REVISIONS		DATE	APPROVED
ZONE	REV	DESCRIPTION	

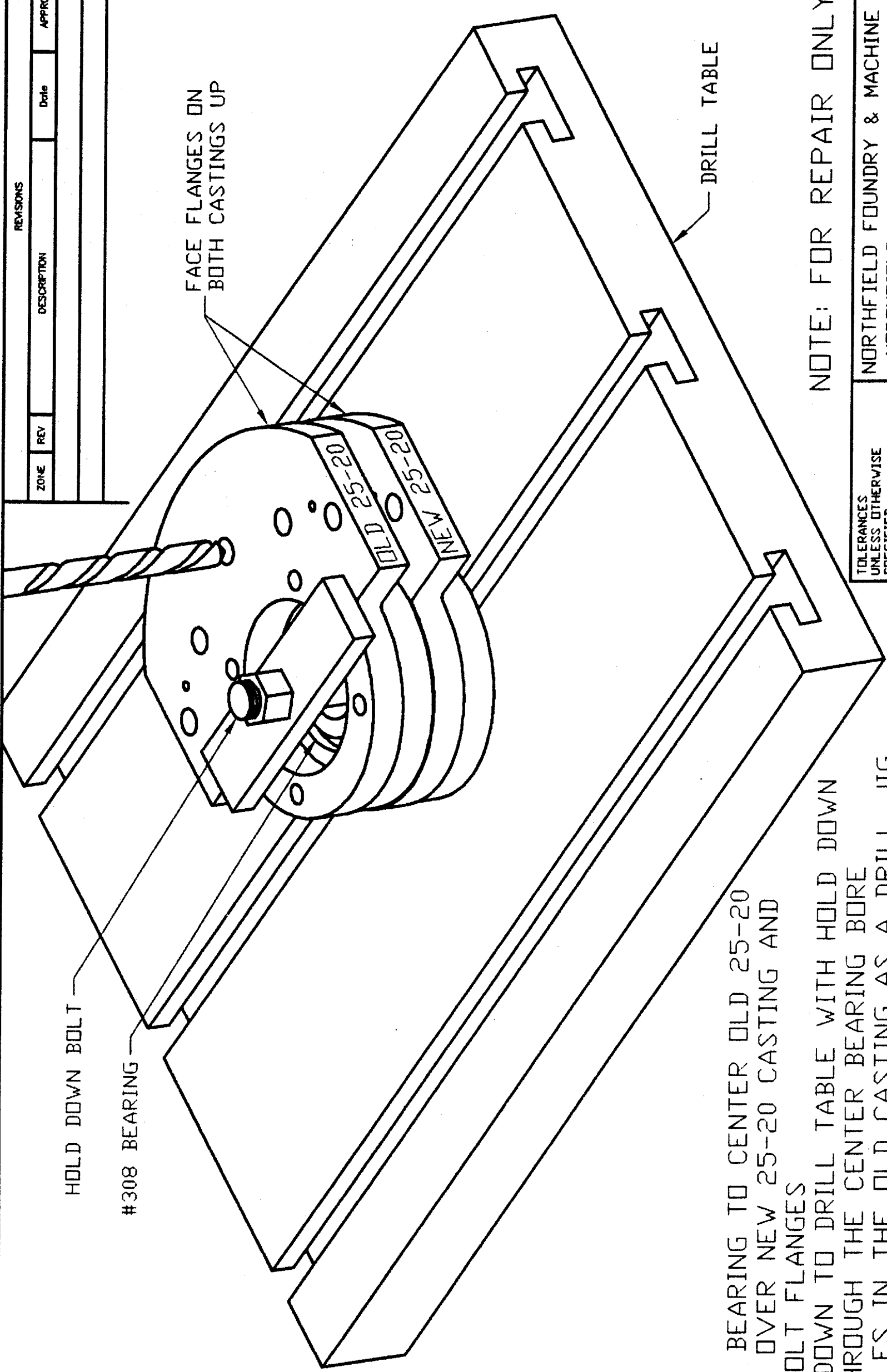

1. USE 308 BEARING TO CENTER OLD 25-20 CASTING OVER NEW 25-20 CASTING AND ALIGN BOLT FLANGES
2. CLAMP DOWN TO DRILL TABLE WITH HOLD DOWN BOLT THROUGH THE CENTER BEARING BORE
3. USE HOLES IN THE OLD CASTING AS A DRILL JIG TO LOCATE HOLES IN NEW CASTING.
4. DRILL THE FIVE CLEARANCE HOLES FOR THE 1/2" BOLTS AND THEN THE 3/16" SPRING PIN HOLES FOR ALIGNMENT.

NOTE: FOR REPAIR ONLY

TOLERANCES UNLESS OTHERWISE SPECIFIED	NORTHFIELD FOUNDRY & MACHINE CO. NORTHFIELD MINNESOTA	
+/- .XX .03	TITLE 25-20 HEAD BRG. DRILLING PROCEDURE	
+/- .XXX .005	SIZE B	DWG NO. 25-681
FRACTION +/- 1/32	DATE 12-13-00	REV A
ANGULAR +/- 1/2 DEG.	Scale 1:2	Sheet 1 OF 1
MATERIAL CAST IRON		
FINISH AS SPEC.		